

# Polaris Ranger 1500 XD - Dual Idler 15% - 73-16774

# Polaris Ranger 1500 XD - Dual Idler 30% - 73-16775

Polaris Ranger 1500 XD (STD Cab & Crew) 4" Dual Idler Portal Kit



**HIGHLIFTER**

**SEIZMIK™**



✉ sales@highlifter.com  
☎ 800-699-0947 | 8:00am - 5:00pm CST  
📍 7455 Atkinson Drive, Shreveport, LA 71129



www.highlifter.com

Parts Available For These Popular Brands and Others

**POLARIS**

**can-am**



**HONDA**

**Kawasaki**

**YAMAHA**

## **PRODUCT DISCLAIMER:**

The installation of products sold or manufactured by High Lifter Products including, but not limited to suspension components such as lift kits, gear reduction lifts, frame stiffener kits, snorkels, and tires that exceed the original specifications for the vehicle, may change the vehicle's center of gravity and handling characteristics both on- and off-road. You are aware that the installation of tires that are larger than original vehicle specifications may reduce the effectiveness of the braking system. Use of these products may place added stress to the original factory vehicle components which could cause them to weaken or possibly fail.

Products sold or manufactured by High Lifter Products are intended for off-road use only. Operation of a vehicle modified with these products on a road could result in serious bodily injury or death, and such operation may violate the laws of your state or municipality. You agree to operate your vehicle exclusively in the manner intended by the vehicle manufacturer. You agree that failure to safely and reasonably operate your vehicle could result in serious bodily injury or death, and that, as a result of installation of this product(s) to your vehicle, extreme care must be taken to prevent vehicle rollover or loss of control, which may be more likely to occur as a result of said modifications. You will avoid unsafe maneuvers, including sudden sharp turns or other abrupt maneuvers, which could make a vehicular accident more likely. You understand that High Lifter Product is not responsible or liable for any damages or any injuries to yourself or your passengers that could occur upon possible accidents due to driver error, incorrect installations, bad judgment, incompatibility with other aftermarket accessories or natural disasters to the fullest extent allowable by law.

You will have all vehicle occupants fasten seatbelts, if equipped, and wear proper safety equipment, such as DOT approved helmet and eye protection prior to operating the vehicle. You understand and acknowledge that failure to wear proper safety equipment may increase the risk of serious bodily injury or death to yourself and any passengers.

Proper installation of products sold or manufactured by High Lifter Products requires knowledge of the factory recommended procedures for removal and installation of original equipment components. Installation of these products without proper knowledge and experience may affect the performance of these components and the safety of the vehicle and cause serious bodily injury or death. It is strongly recommended that a certified mechanic familiar with the installation of similar components perform the product(s) installation.

Prior to installing any products sold or manufactured by High Lifter Products, you will perform or cause to be performed an inspection of their vehicle to confirm its condition is suitable for the installation of these products. A proper inspection of the vehicle includes confirmation that the vehicle has not been in a collision and is free of corrosion. If the vehicle is suspected to have been in a collision or misused, or is otherwise unsuitable for modification, you will not install the product(s). You will continue to inspect the vehicle prior to each use to confirm its condition is suitable for its intended use, and you acknowledge that the failure to do so may result in serious bodily injury or death, as well as damage to the vehicle itself.

You will install any warning labels provided with the product so it may be prominently seen by yourself and all passengers. You will notify all passengers of the modifications performed to your vehicle prior to operation.

Insurance companies may handle coverage of a modified vehicle differently. Please check with your insurance carrier prior to modifying the vehicle to ensure your coverage remains sufficient.

Installation of this product(s) may void your vehicle warranty. If this is a concern, please check with the manufacturer or dealer before purchase or installation of this product(s).

## INTRODUCTION

---



READ THESE INSTRUCTIONS CAREFULLY. IT IS RECOMMENDED THAT A PROFESSIONAL MECHANIC PERFORM THE INSTALLATION. CARE SHOULD BE TAKEN TO FOLLOW ALL STANDARD SAFETY PROCEDURES.

**PRIOR TO INSTALLATION**, A THOROUGH INSPECTION OF THE SUSPENSION SHOULD BE MADE. INSPECT THE VEHICLES STEERING, DRIVELINE, AND BRAKE SYSTEMS, PAYING CLOSE ATTENTION TO THE SUSPENSION LINK ARMS AND BUSHINGS, ANTI-SWAY BARS AND D BUSHINGS, TIE ROD ENDS, BALL JOINTS AND WHEEL BEARINGS.

ALSO CHECK THE STEERING SECTOR-TO-FRAME AND ALL SUSPENSION-TO-FRAME ATTACHING POINTS FOR STRESS CRACKS. THE OVERALL VEHICLE MUST BE IN EXCELLENT WORKING CONDITION. ANY WORN, BENT OR BROKEN PARTS SHOULD BE REPAIRED AND/OR REPLACED.

**NOTE:** DO NOT ADD OR FABRICATE ANY COMPONENTS TO GAIN ADDITIONAL SUSPENSION HEIGHT.

**NOTE:** AFTER INSTALLATION, ANOTHER INSPECTION SHOULD TAKE PLACE, CHECKING FOR LOOSE COMPONENTS OR MISSING HARDWARE. INSPECT, AGAIN AFTER EIGHT (8) HOURS OF OPERATION. REMEMBER TO CHECK THE LUG NUTS AGAIN.

**NOTE:** A FACTORY SERVICE MANUAL SHOULD BE ON HAND FOR REFERENCE. THE MANUAL WILL CONTAIN FASTENER TORQUE SPECS, ASSEMBLY TECHNIQUES, AND SPECIAL TOOL REQUIREMENTS THAT ARE UNIQUE TO THIS PARTICULAR YEAR AND MODEL VEHICLE.

## REQUIREMENTS

---



### TOOLS

- Jack Stand
- Metric & standard socket assortments
- Metric & standard hex key/sockets
- Torque wrench
- Multi-purpose pliers
- Wire cutter/snips
- Mallet (Soft face hammer)
- Drift punch/pin
- Vice or Press



### WHEEL REQUIREMENTS

- 14" or larger wheel required
- Cannot exceed 5" backspacing
- Not compatible with dual bead lock wheels
- 1" wheel spacers required on stock wheels



### SUPPLIES

- Water-resistant grease
- DOT 4 brake fluid
- 80w90 gear oil

#### The product is/will:

- Designed and intended for use on a UTV at slow speeds.
- Increase the center of gravity.
- Increase the turning radius.
- Increase the stopping distance when adding larger tires.
- Increase and accelerate wear of factory components including bushings, bearings, ball joints, and tie rod ends.
- We cannot guarantee fitment with other aftermarket accessories.

#### Safety Guidelines:

- Inspect all moving factory suspension components particularly ball joints, tie rod ends, control arm connections, and brakes prior to each ride and replace if worn.
- Inspect clearances with control arms and brake lines prior to each ride.
- 14" or larger wheels must be used with the Portal Gear Kit. 12" wheels cannot be used.
- Jumping, high speeds, and quick maneuvering should be avoided.

#### Maintenance Information:

- Check gear oil in portal boxes following 25 hours of riding or sooner, depending on how you ride.
- Use 4 oz of SAE 80W-90 Gear Lubricant as needed in each portal box.
- Replace worn factory components including bushings, bearings, ball joints, brakes, and tie rod ends when they show wear.

Any vehicle equipped with a Portal Gear Kit must have the enclosed large format "Warning to Driver" decal installed on the inside of the windshield or on the vehicle's dash, within driver's view. The "Warning to Driver" decal is to act as a constant safety reminder for whoever may be operating the vehicle.

**INSTALLING dealer:** It is your responsibility to install the "Warning to Driver" decal and forward these installation instructions to the vehicle owner for review of warnings, product use, and maintenance information. Replacement Warning Decals are available FREE on request. These instructions are to be kept with the vehicle registration papers and owner's manual for the service life of the vehicle.

#### REFUSED Shipments/Order CANCELLATION:

Refused shipments are subject to a 20% restocking fee plus all associated freight costs. It is our goal to ship all orders in a timely manner. If a customer wishes to cancel an order (provided it is not a special-order product), it is the responsibility of the customer to cancel the order prior to the product being shipped. If a customer cancels an order after product has been shipped, refused shipment, cancellation, or return will be subject to a 20% restocking fee and any freight charges incurred. For orders outside the United States, any fees associated with customs or duties are non-refundable.

#### DAMAGED Shipments:

All claims for damaged shipments must be made within 72 hours of delivery to the point of destination. Any damage to package should be noted with carrier at the time of delivery if possible. We will not be responsible for damage claims made over 72 hours after delivery to the point of destination.

## PARTS DIAGRAM

### HARDWARE & BRAKE LINES (PGLBOX-P416-D1-B1)



**PGLC-SOCKET46MM**  
73-14784  
46mm Socket (1ea)



**73-16761**  
Brake Caliper Bracket (2ea)



**73-14688**  
Portal Brake Caliper Bracket (2ea)

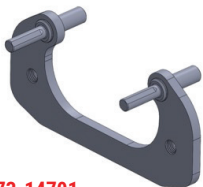

**73-14701**  
Brake Caliper Hanger Bracket (2ea)



**54-60936**  
HIGH STRENGTH TRD LOCK  
1.8ML (RED) (1ea)



**54-61024**  
MFB10X1.25X25-10.9  
(4ea)



**73-14796**  
M12X1.5 WHEEL  
STUD (20ea)



**73-14779**  
1/2" BRAKE ROTOR  
SPACER (26ea)



**54-60500**  
BSH 3/8x1" BUTTON HD  
(16ea)



**54-60937**  
MED STRENGTH TRD LOCK  
1.8ML (BLUE) (1ea)



**73-14665**  
M20-1.5 FLANGE  
SHOULDER AXLE NUT  
(4ea)



**73-13216**  
5/32" x 2"  
COTTER PIN  
(4ea)



**5460833** 1/2" x 4- 3/4"  
Hex Bolt (4ea)



**5460832** 1/2 X 4 1/2 GR8  
Hex Bolt (12ea)



**54-60751** 1/2" SAE Flat  
Washer Zinc (32ea)



**54-61093** 1/2-13 NYLON  
LOCKNUT GR8 (16ea)



**54-61003**  
5mm x 0.80 x 20mm  
Hex Head Bolt (4ea)



**54-61002**  
5mm x 0.80 x  
16mm Hex Head  
Bolt (4ea)



**54-61030**  
5mm Metric Flat  
Washer (8ea)



**54-61041**  
5mm-0.80 Metric  
Lock Nut (8ea)



**54-61341** 8" Zip Ties (14ea)



**79-84445**  
Bushing Kit (1ea)



**73-15076**  
Loom Clamp  
(12ea)



**79-15281**  
0.5"-90 Brake  
Line Extension (1ea)

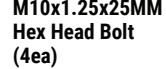

**54-96498**  
M10x1.25x25MM  
Hex Head Bolt  
(4ea)



**79-11622**  
Steering Stop (2 ea)

### HUB & ROTOR (PGLBOX-HRB-404)



**146A** Brake Rotor  
(2ea)



**PGLC-Rotor-6**  
Brake Rotor (2ea)

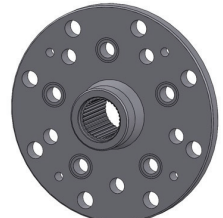

**PGLC-Hub-204**  
(4ea)

### FRONT BACKING PLATES (PGL-BOX-C403-DI-B2B1)

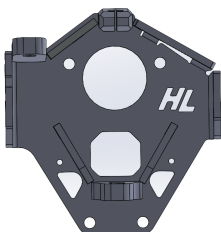

**79-84323-L-B1**  
Left Front Portal Backing  
Plate (1ea)

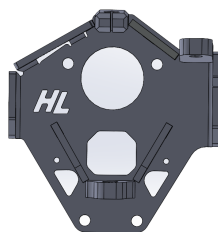

**79-84323-R-B1**  
Right Front Portal  
Backing Plate (1ea)

### PORTALS

Portal Assembly (4ea)



**FRONT**  
**73-16778** (30%)  
**73-16776** (15%)  
**REAR**  
**73-16779** (30%)  
**73-16777** (15%)

### REAR BACKING PLATES (PGL-BOX-C403-DI-B3B1)

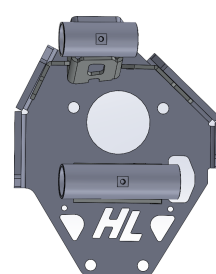

**79-84338-L-B1**  
Left Rear Portal Backing  
Plate (1ea)

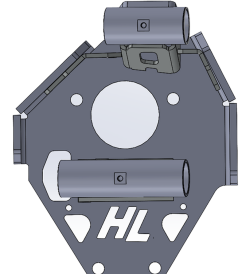

**79-84338-R-B1**  
Right Rear Portal Backing  
Plate (1ea)

NOTE : Rear portal boxes will have a brown seal at input shaft location, Front portal boxes will have black.

# FRONT INSTALL

## PREPARE VEHICLE

## REMOVAL

1



### FRONT

Begin by loosening the lug nuts on both front tires.

Using a suitable lifting device or jack, raise the unit until the front tires are off the ground an additional 4".

If using a floor jack with stands, chock the rear wheels to prevent the unit from rolling. If using jack stands, make sure the stands are placed under the frame and not the body.

Make sure the unit is stable and secure.

Remove lug nuts and front wheels.

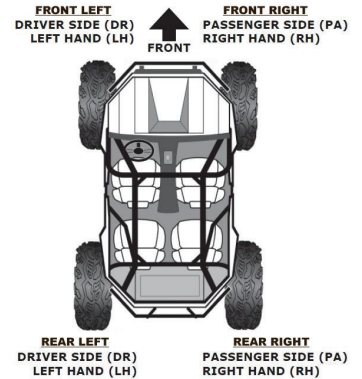

## BRAKE CALIPER AND BRAKE LINES

## REMOVAL

2

a. Remove the cotter pin and the front wheel hub castle nut.

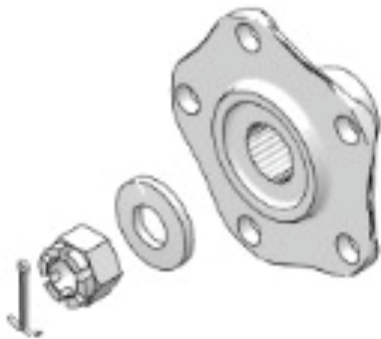

b. Remove the scrapers from the front rotors. You will not reuse these. Next remove the hub/rotor.

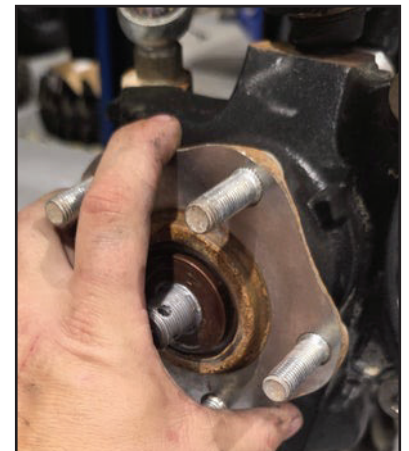
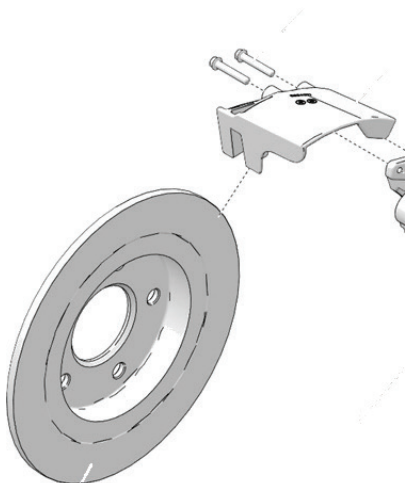

c. Remove the upper & lower caliper mounting bolts. Retain the factory bolts & nuts.

d. It is not necessary to remove the brake line from the caliper yet. Leave the brake hose attached to the caliper and hang the calipers out of the way. Take precautions to ensure the brake hose isn't stretched or pinched.

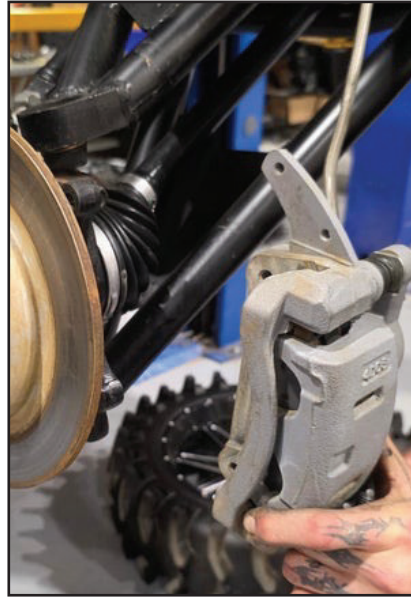

e. Disconnect the tie rod.



f. Remove the upper ball joint from the knuckle. You may need a mallet to break it free.



g. Remove the lower ball joint from the knuckle.



h. Remove the knuckle and retain factory hardware.

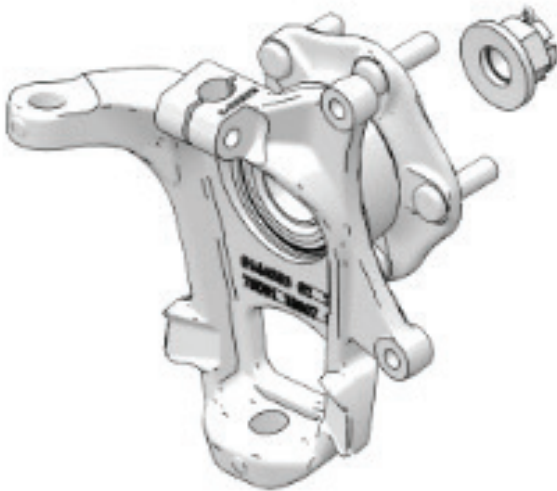

**NOTE:** If you are having trouble removing the upper ball joint, unbolt the lower shock and sway bar.

## STEERING STOP

---

3

**NOTICE: DO NOT remove the steering rack assembly. The images featured are for DEMONSTRATIVE PURPOSES ONLY.**

### BOOT REMOVAL

The rubber boots on the rack and pinion are held on by zip ties. You will need to cut the zip tie that secures the boots to the inside of the rack and pinion.

### START WITH THE DRIVER'S SIDE

This side has the least amount of room. Once you install the spacer on the passenger side you will have less play on the driver's side. **DO NOT REMOVE THE FACTORY SPACER ALREADY IN PLACE.** Turn the steering wheel all the way to the **RIGHT**. Place (1) steering stops between the inner tie rod joint and the rack and pinion.

### PASSENGER SIDE

Turn the steering all the way to the left. Place (1) steering stops between the inner tie rod joint and the rack and pinion. It is a tight fit, so you may have to force it on, this is to ensure that the spacer stays in place.

### RE-SECURING BOOT

Turn the steering wheel closer to the center to allow play in the boot.

Slide the boot back down and secure it with an 11" zip tie.

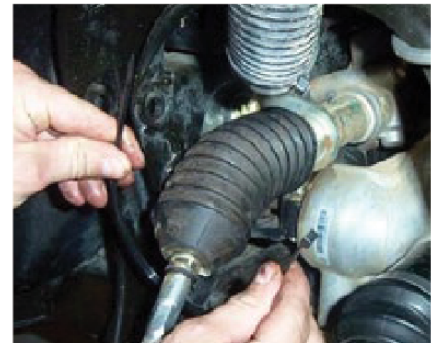
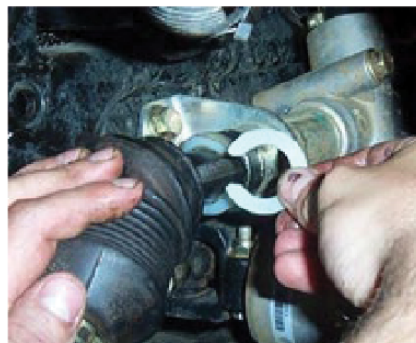
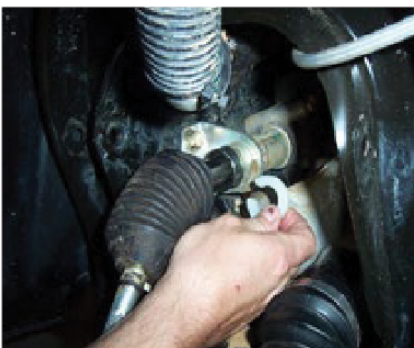
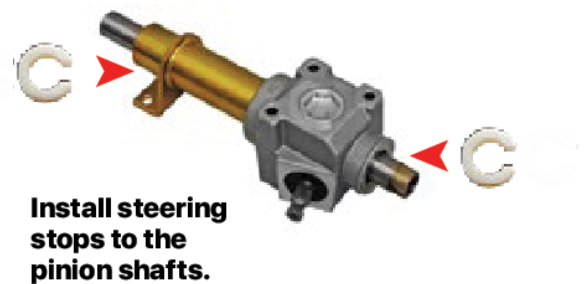

4

- a. Find the front backing plates 79-84323-L-B1 and 79-84323-R-B1.
- b. Insert the drive shaft into the backing plate. Place the upper ball joint into the upper ball joint mount bracket. Fasten it with the factory hardware. (18mm) [50 ft lbs]
- c. Place the lower ball joint into the lower ball joint mount bracket. Fasten it with the factory hardware. (18mm) [50 ft lbs]

**NOTE:** You may need to clean powder coating from the hole.

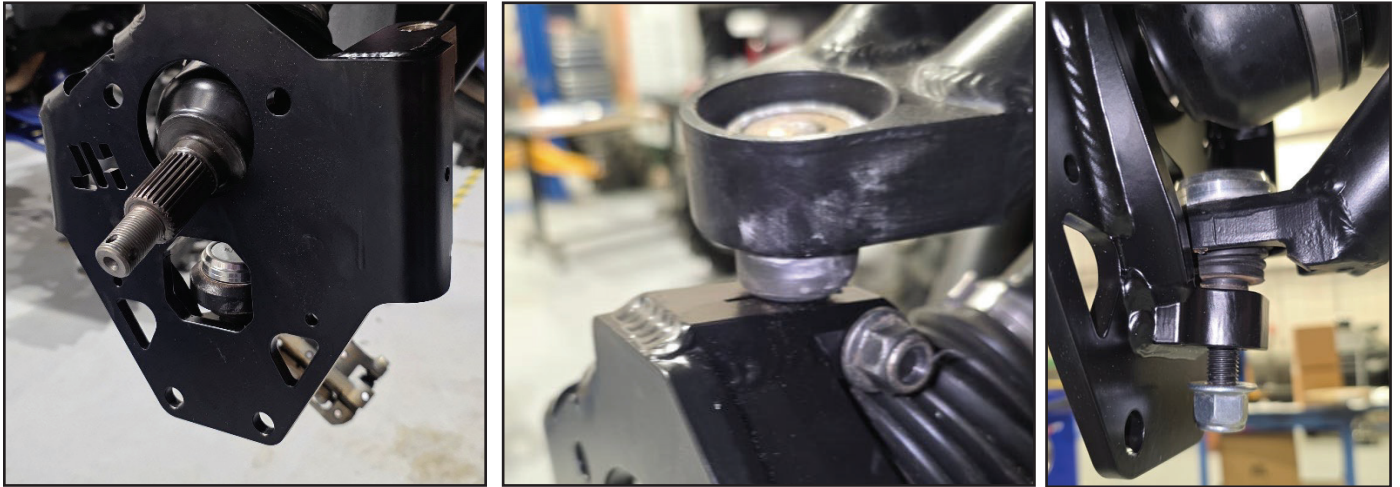

5

- a. Find the caliper mounting bracket 73-16761 and place it in the corresponding fitted FRONT section of the portal box.

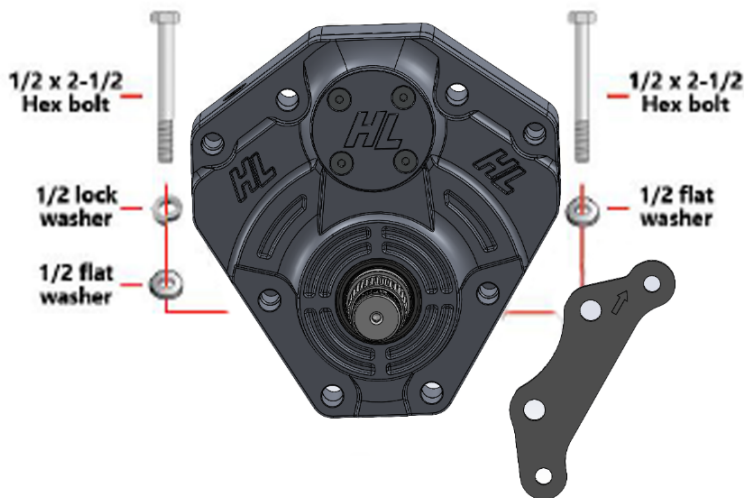

**FRONT**

Install the 73-16761 caliper bracket facing the FRONT of the vehicle.

**YOU MUST DISCARD THE PRE-INSTALLED LOCK WASHER.**

The bolt head should sit flush with the bracket.

**REAR**

Each side has pre-installed hardware on the portal box.

The installment should look like the featured diagram when complete.

6

- a. Apply water-resistant grease to the drive splines. Be sure to apply product all around the outer edge as well.
- b. Rotate the portal box assembly 'Up & In' as you guide the drive shaft axle through the inner drive gear.



- c. Insert the bolts through the corresponding holes in the backing plate.

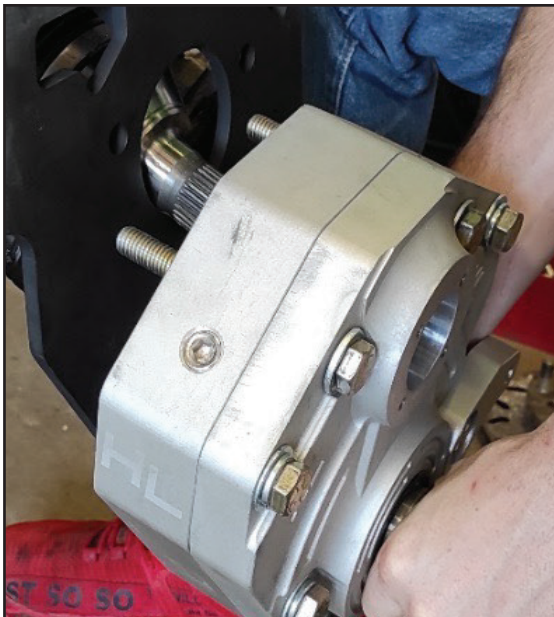

**Loosely fasten all (4) bolts with 1/2" flat washers and 1/2" lock nuts. Ensure parts fit correctly then torque. (3/4) [105 ft lbs.]**



- d. Install the tie rod end into the backing plate tie rod mount bracket. Fasten the tie rod end with the factory hardware. (18mm) [90 ft lbs.]

**NOTE:** All steering mounting points are designed to match factory dimensions and specifications. If you install aftermarket steering or suspension components, follow the manufacturer's instructions for any required changes. This is especially important if mounting hardware differs from factory specifications..

7

- a. With the portal box assembly in place, double check that the factory axle shaft is properly aligned into the drive gear of the portal box.
- b. Apply LOCTITE (BLUE) to the supplied M20 axle nut with shoulder PGLC-AXNUT-5, then tighten & torque onto the drive shaft axle. (30mm) [20 ft lbs]

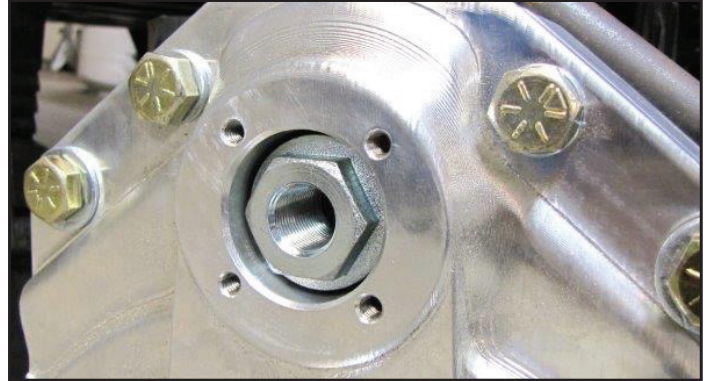

- c. Align the portal box lid cap & gasket. Use the 1/4-20 x 3/4" screws and install to the box. (5/32) [8 ft lbs]

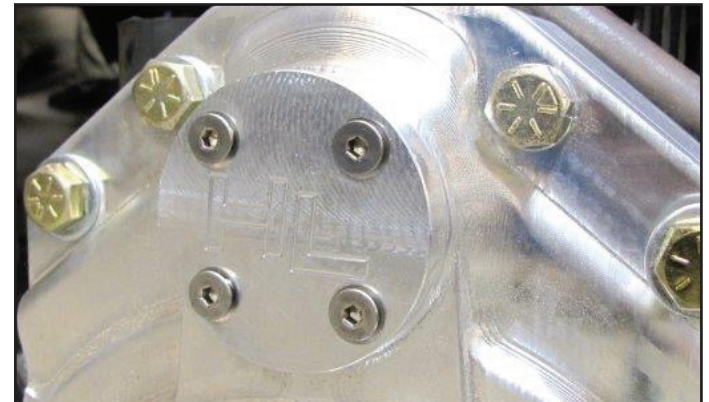
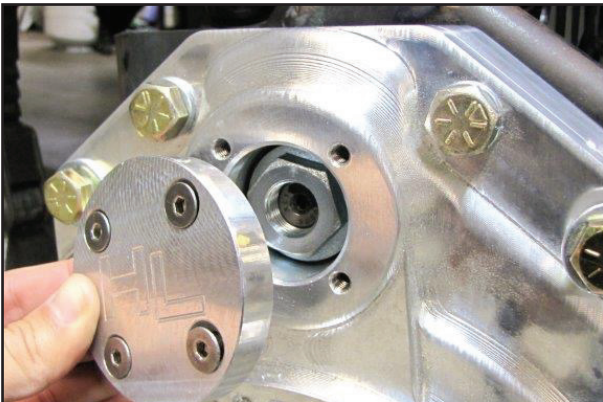

**8** Assemble all brake rotors as shown.

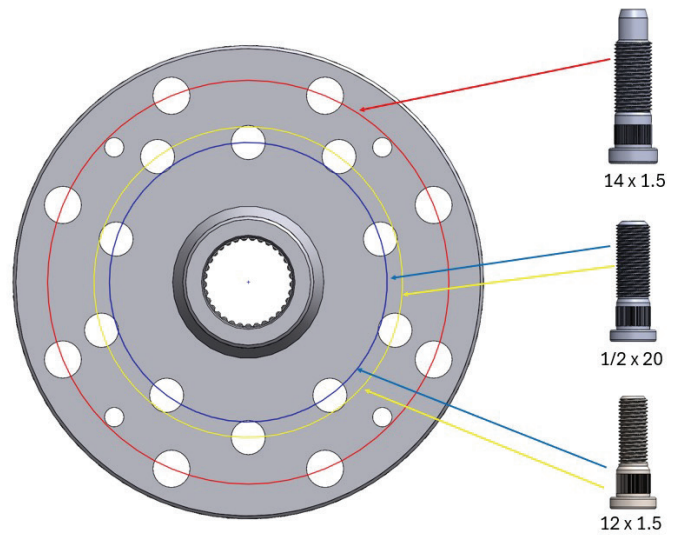
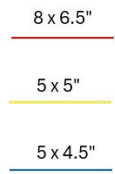

**9** Assemble all wheel hubs as shown.



**NOTE:** This side will face away from the UTV when installed.

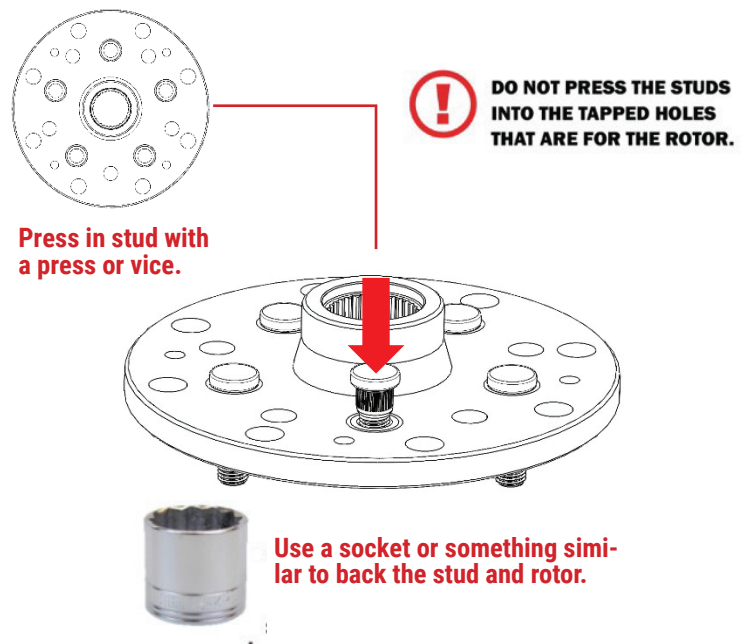

a. Place the 1/2" spacers over the tapped holes. These spacers go **BETWEEN** the hub and rotor.

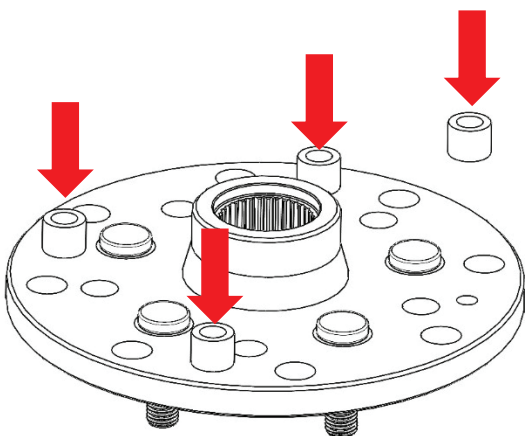

b. Install the rotor and secure it to the hub by applying LOCTITE (RED) to the (4) 3/8 x 1-1/4" button head bolts. [45 ft lbs]

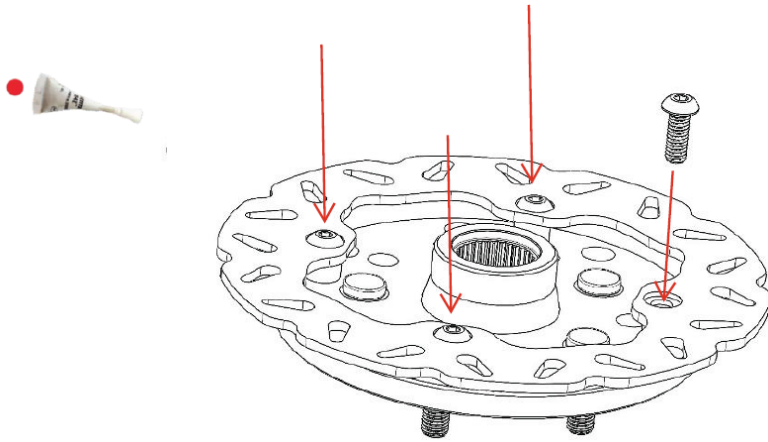

## BRAKE ROTOR ASSEMBLY

## INSTALL

10

a. Apply water resistant grease to the spindle splines and slide the brake rotor assembly onto the spindle shaft.

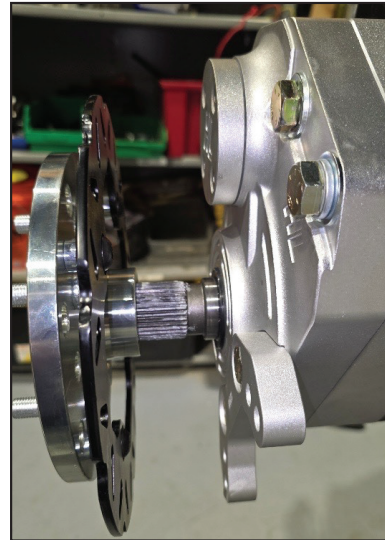

b. Slide on the supplied 30mm lock washer, followed by the 30mm spindle castle nut. (46mm) [Min 120 ft lbs] Tighten the castle nut further if needed to align grooves with holes in the spindle for the cotter pin. Install the supplied cotter pin. Both ends of the cotter pin must be folded.

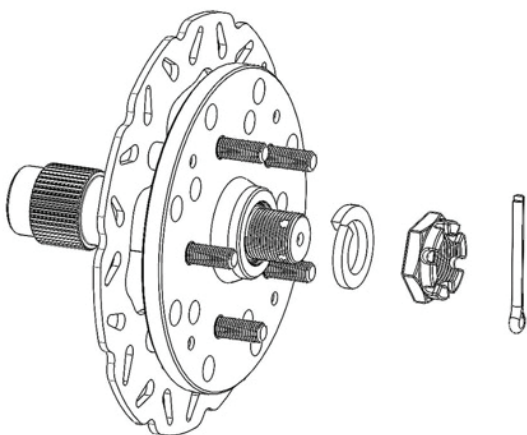

11

- a. Disconnect the front calipers from the factory brake lines. Have a container to collect brake fluid.
- b. Install the caliper onto the portal box between the new caliper bracket and rotor. Use the factory mounting bolts. (15mm) [30 ft lbs]

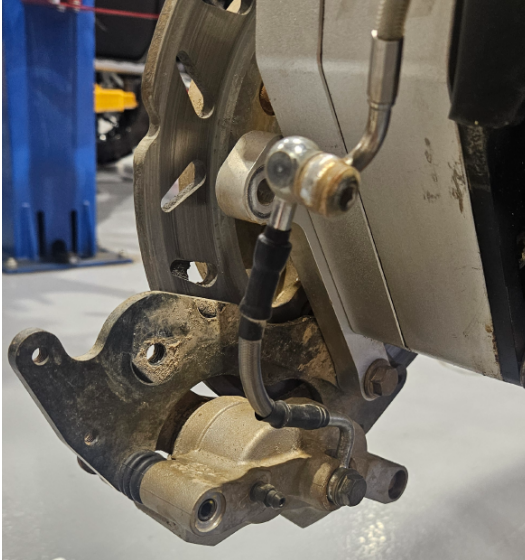

**NOTE:** Remember, the bleed off valve always goes to the TOP of the caliper.

# REAR INSTALL

## PREPARE VEHICLE

12

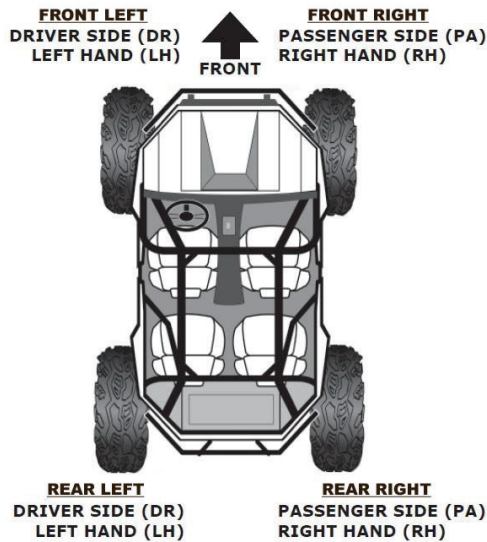

## REAR

Begin by loosening the lug nuts on both rear tires. Using a suitable lifting device or jack, raise the unit until the front tires are off the ground an additional 4".

If using a floor jack with stands, chock the front wheels to prevent the unit from rolling. If using jack stands, make sure the stands are placed under the frame and not the body.

Make sure the unit is stable and secure. Remove lug nuts and rear wheels.

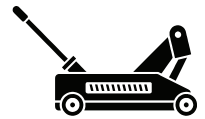

## REAR BRAKE CALIPERS & HUBS

## REMOVAL

13

- a. Remove the scraper and discard. This will not be reused.



- b. Remove the upper & lower caliper mounting bolts. Retain the factory bolts & nuts. They will be reused during the installation of the Portal Boxes & Mounting Brackets. (15mm)
- c. Remove the caliper from the rear hub. It is not necessary to remove the brake line from the caliper at this time. Leave the brake hose attached to the caliper and hang the calipers out of the way. Take precautions to ensure the brake hose isn't stretched or pinched.

- d. Remove the cotter pin and loosen the rear wheel hub castle nut (27mm). Remove the nut from the rear wheel hub assembly. Then remove the brake rotor assembly.

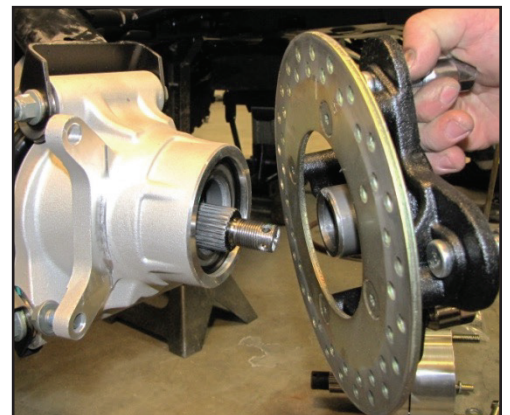
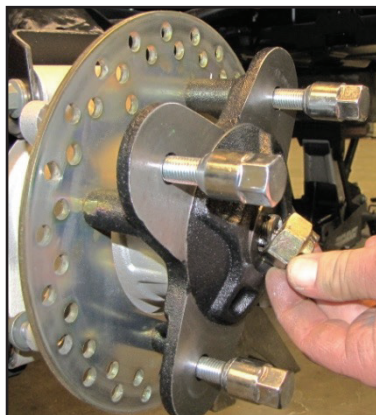

- e. Note: Image is showing 4 stud, your machine will be 5. Process is the same.

e. Remove the bolts and nuts that attach the rear knuckle to the upper & lower A-arms. Retain the factory hardware. They will be reused during the installation of the Portal Boxes & Mounting Brackets. (15mm)

f. Remove the rear knuckle.

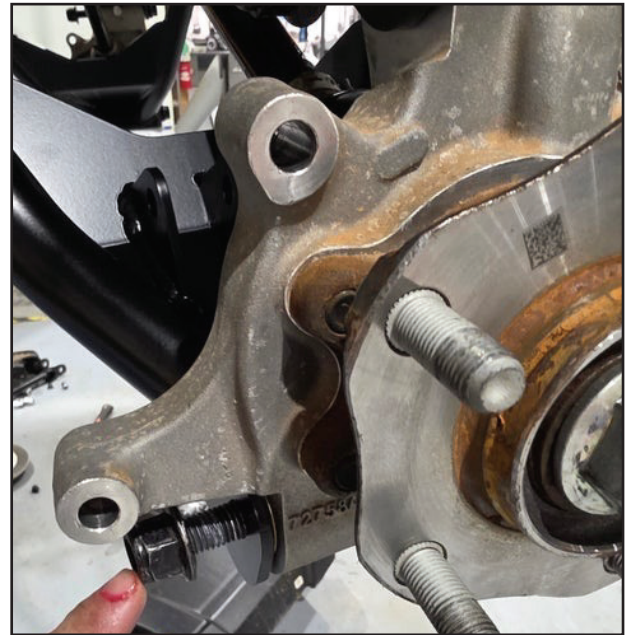

## BUSHINGS - BACKING PLATE ASSEMBLY

**INSTALL**

14

Install the bushings into the backing plate assembly

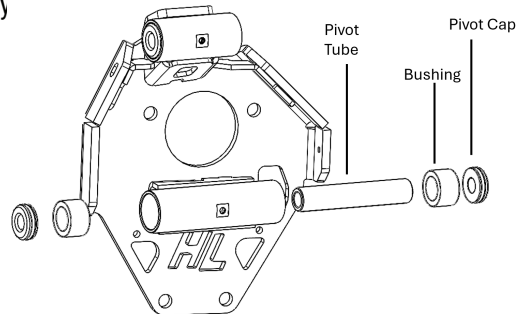

## BUSHINGS - BACKING PLATE ASSEMBLY

**INSTALL**

15

a. Place the backing plate into position on the control arms and guide the drive shaft through. Using the factory hardware, fasten to the lower control arm. (15mm)[90 ft. lbs] Then fasten to the upper control arm. (15mm)[50 ft. lbs]



16

- a. Find your assembled rear portal box.
- b. Find caliper mounting bracket PGLC-BCB-118o and place it in the corresponding fitted REAR section of the portal box. Then insert a 1/2 x 4-3/4" bolt and 1/2" washer into the bracket holes & box.
- c. Slide a 1/2" flat washer onto (4) 1/2 x 4-1/2" bolts and insert them into the remaining four holes of the box.

REAR PORTAL BOX ASSEMBLY

INSTALL

17

- a. Apply water-resistant grease to the drive splines.
- b. Rotate the portal box assembly 'Up & In' as you guide the drive shaft axle through the inner drive gear.
- c. Insert the bolts through the corresponding holes in the backing plate.

**NOTE:** Due to the longer length and geometry of the axle joint, it will not sit flush to the cupped seal in the portal box once inserted all the way. The seal is designed to work universally, and this is normal.

- d. Loosely fasten the bolts with 1/2" flat washers and 1/2" lock nuts. Recheck all parts that were used and make sure everything fits correctly, and then go ahead and tighten and torque all bolts. (3/4)[105 ft lbs]

REAR DRIVE SHAFT JAM NUT, SPINDLE SPACER & PORTAL BOX LID CAP

INSTALL

18

- a. With the portal box assembly in place, double check that the factory axle shaft is properly aligned into the drive gear of the portal box.
- b. Apply **LOCTITE (BLUE)** to the supplied M18 flanged axle nut **73-14665** then tighten & torque onto the drive shaft axle. (30mm)[20 ft lbs]



- c. Align the portal box lid cap & gasket. Use the 1/4-20 x 3/4" screws and install to the box. (3/16)[8 ft lbs]



19

- a. Apply water resistant grease to the spindle splines and slide the brake rotor assembly onto the spindle shaft.

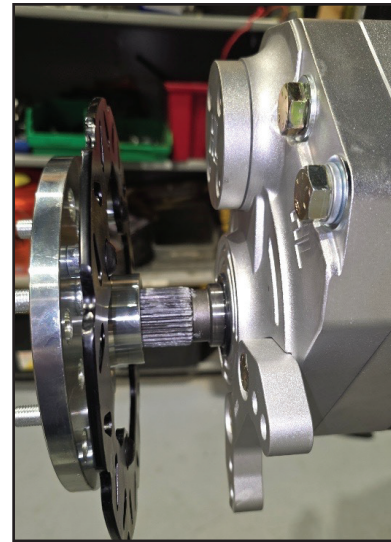
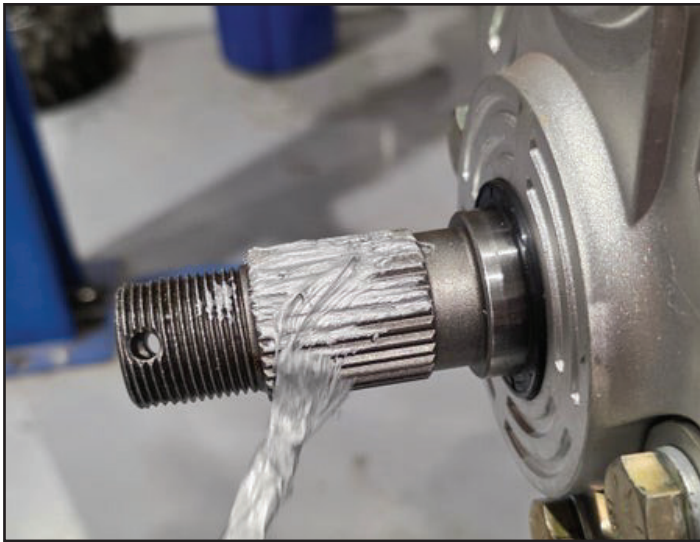

- b. Slide on the supplied 30mm lock washer, followed by the 30mm spindle castle nut. (46mm) [Min 120 ft lbs] Tighten the castle nut further if needed to align grooves with holes in the spindle for the cotter pin. Install the supplied cotter pin. Both ends of the cotter pin must be folded.

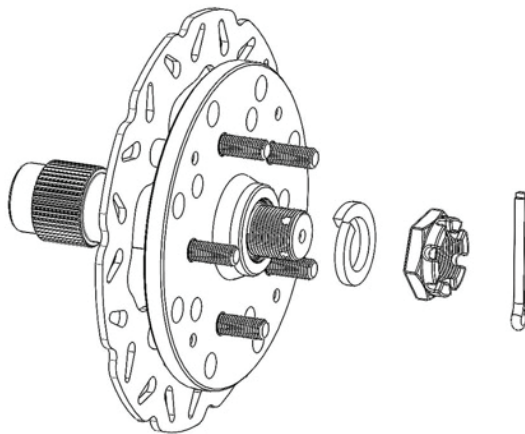

20

## FRONT & REAR BRAKE LINE EXTENSION

Locate the proper BRAKE LINE EXTENSION. Using the supplied button head hex drive banjo bolt, connect the STOCK BRAKE LINE to the BLIND-END BRAKE LINE EXTENSION. Ensure the copper washer are on each side of the banjo fitting.

NOTE: Verify that the back of the blind hole fitting (rounded portion) is facing INWARD towards the center of the unit.

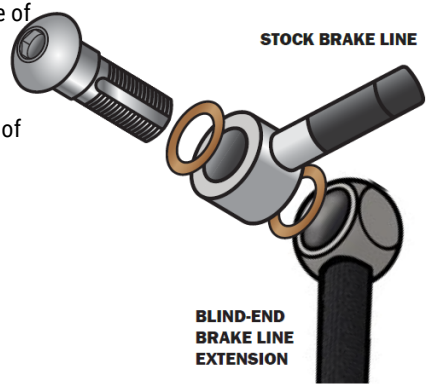

## EXTENSION TO CALIPER INTALL

On the opposite end, connect the REQUIRED BRAKE LINE EXTENSION to the stock brake caliper. Verify there is a copper washer on each side of the banjo fitting. Position the fitting like the photo previewed.

## BACKING PLATE

Secure the brake line to the rear of the portal backing plate by using a p-clamp. Insert a 5mm x 20mm bolt through the 5mm washer and 5mm lock nut.

NOTE: Ensure that there is no binding, pinching or interference with moving parts or sharp edges and the brake lines.

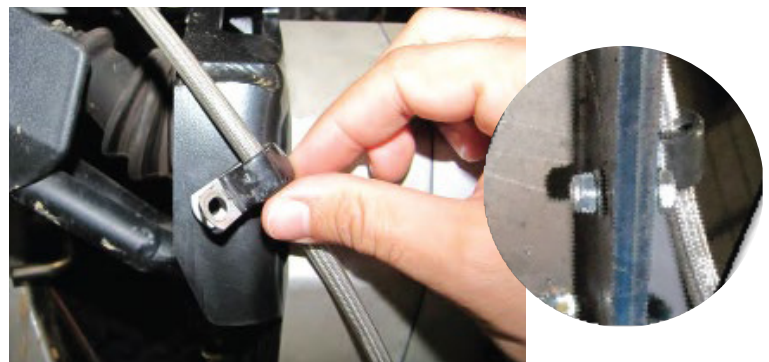

REPEAT STEPS ON OPPOSITE SIDE

21

**NOTE: USE DOT 4 BRAKE FLUID**

**CAUTION: ALWAYS wear eye protection like safety glasses. Brake fluid will damage finished surfaces. Do not allow brake fluid to come in contact with finished surfaces.**

1. Bleeding the brakes is a two person job; you will need someone at the brake caliper and someone to pump the brake foot pedal. Take precautions due to the vehicle being on jacks and/or jack stands.
2. Clean the master cylinder cover thoroughly and remove the cover.
3. With all bleeder screws open, a gravity bleed is recommended to start with. This will push all the air out at once and eliminate most of the air bubbles. (Have area prepared for spills and cleaning)
4. Add brake fluid to the indicated MAX level of the reservoir. (Any DOT 4 Brake Fluid)
5. Close off each line once you steadily see fluid coming out.
6. Begin final bleeding procedure with the caliper that is the farthest from the master cylinder. It should be this sequence - (PA) REAR, (DR) REAR, (PA) FRONT, and then (DR) FRONT.
7. You can use the supplied clear hose to attach to the caliper bleeder screw. Be sure the hose fits tightly on fitting. Now place the other end of the hose into a clean container.
8. Install a box end wrench on the caliper bleeder screw. Have your brake buddy slowly pump the foot pedal until pressure builds and holds. Have your buddy hold brake pedal down to maintain pedal pressure. Now slowly open the caliper bleeder screw 1/4" turn so the air and fluid will displace into the container.
9. Close bleeder screw, and then have your buddy release the foot pedal.

**NOTE: Do not release foot pedal before the bleeder screw is tight or air may be drawn into the master cylinder... and you have to start all over again!**

10. Repeat steps until clean fluid appears in the bleeder hose & all the air has been purged... Close bleeder screw, pump brakes, hold pressure, open bleeder, close bleeder, release foot pedal, check master cylinder.
11. Check the master cylinder fluid level.  
**NOTE: You must maintain at least 1/2" (1.27cm) of brake fluid in the reservoir to prevent air from entering the master cylinder.**
12. Tighten bleeder screw securely and remove bleeder hose. Torque the bleeder screw. [4 ft lbs]
13. REPEAT procedure steps for the other three (3) brake calipers in the sequence listed above.
14. Add brake fluid to MAX level inside master cylinder reservoir after the last caliper is completed. Install master cylinder reservoir cover. Check brake system for leaks.
15. Once completed, dispose of used fluid properly.

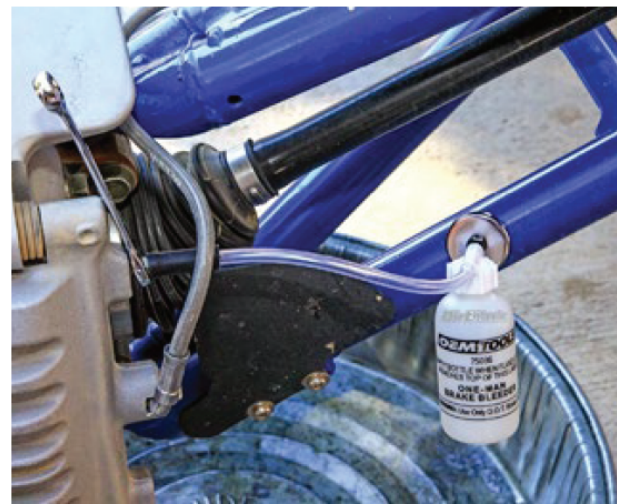
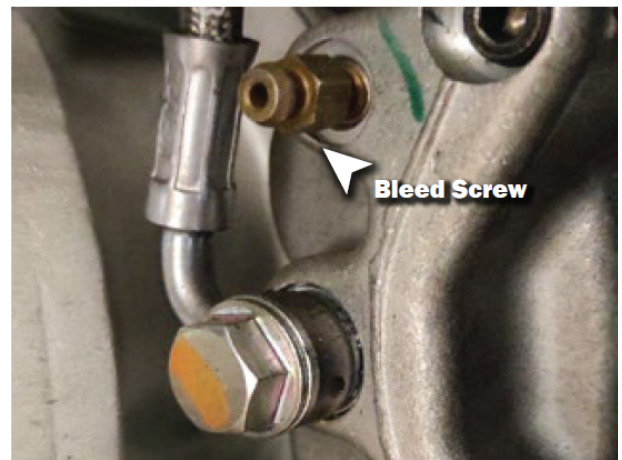

## FILL PORTAL BOXES WITH OIL

22



**DO NOT USE AN IMPACT TOOL ON ANY PLUGS.**



**ALL PLUGS MUST BE LUBRICATED OR WRAPPED IN TEFLON TAPE. PLUGS MAY NOT SIT FLUSH. DO NOT TIGHTEN TO MORE THAN 10FT LBS OF TORQUE.**

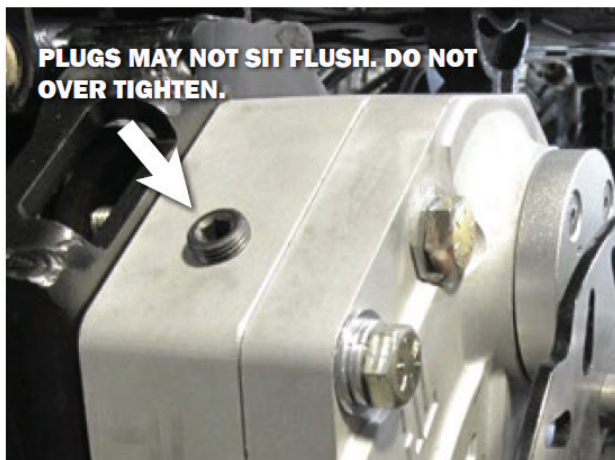

**Use SAE 80W-90 oil. This gear lubricant is designed for gears operating under severe temperature and load conditions. SAE 80W-90 viscosity grade offers extended performance.**

23

## WHEEL INSTALL

- A. Install wheel lug nuts and securely tighten.
- B. Remove all jacks, jack stands, and other devices used to lift and hold the vehicle.
- C. With the suspension supporting vehicle weight, torque the wheel lug nuts using an "X" tightening pattern

Aluminum Wheels = [90 ft lbs]

Steel Wheels = [50 ft lbs]

**WARNING:** Retighten lug nuts at eight (8) hours after any wheel change or anytime wheel nuts are loosened. Failure to do so could cause wheels to come off while the vehicle is in motion.

This is a warning and reminder.

- a. Ensure the vehicle is positioned securely and 'Level'.
- b. Use SAE 80W-90 oil. This gear lubricant is designed for gears operating under severe temperature and load conditions, and whose SAE 80W-90 viscosity grade offers extended performance.

- c. On the top of the box is the vent hole and plug, make sure the threads are wrapped in Teflon tape or lubricated with oil or grease. Using an Allen wrench, make sure the plug is tightened. [10 ft lbs] (8mm) **NOTE: A optional vent line kit will be available to purchase in the future.**

- d. On the bottom of the box is the drain hole and plug. Make sure the plug is wrapped in Teflon tape or lubricated with oil or grease. Tighten to [10 ft lbs] (8mm)

- e. On the lower backside of the backing plate is an opening for the portal box fill hole and plug. (It is always toward the front of the vehicle.) Remove the fill plug. (8mm)

- f. Take the gear oil bottle and fit the spout into the fill hole. You can gently 'Squeeze' the bottle to help the process.

- g. Fill the portal box until the fluid starts draining back out of the fill hole. Then reinstall the fill plug, wrap the threads with Teflon tape or lubricate threads with oil or grease. [10 ft lbs]



**Caution: Do not over fill past the fill plug. If the oil heats up or expands, it will cause the oil to exhaust out the axle seal.**

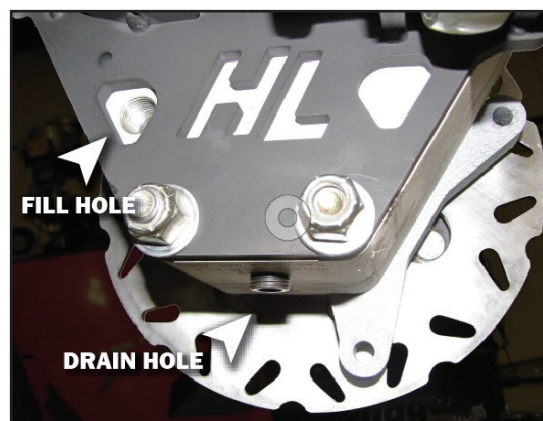

## FRONT WHEEL ALIGNMENT

24

**IF YOU HAVE ADJUSTABLE CONTROL ARMS, YOU MUST ADJUST THE CAMBER FIRST BEFORE PROCEEDING. DO NOT INSTALL WHEELS ONTO UTV UNTIL PROPER ALIGNMENT HAS BEEN ACHIEVED.**

- Straighten steering wheel
- Make sure that the brake rotors are straight to sight or level.
- Using a tape measure, measure from inside to inside on the front and back ends of the rotors.

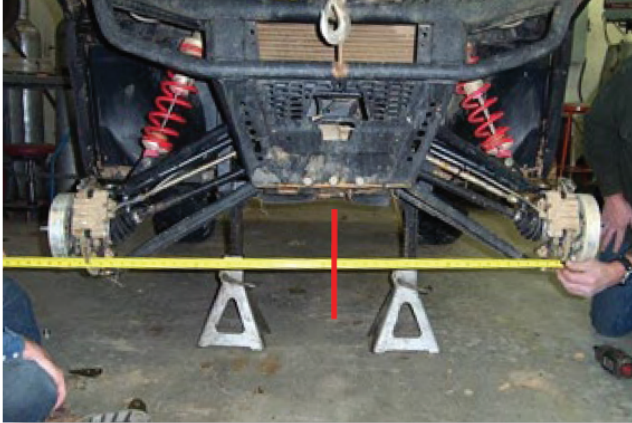

### **INCORRECT TOE**

If the toe alignment is incorrect, measure the distance between vehicle center and the back of the rotors. This will indicate which tie rod needs adjustment.

### **ADJUSTING TOE**

Adjust tie rods until **BOTH** measurements are the **SAME**, then adjust toe tolerance.

The recommended vehicle toe tolerance is 1/8" to 1/4" (3.175-6.35mm) toe out. This means the **FRONT MEASUREMENT IS WIDER THAN THE REAR MEASUREMENT.**

### **TOE ADJUSTMENT CHART**

<b>TOE (Inches)</b>	1/16	1/8	3/16	1/4	5/16	3/8
<b>TOE (Degrees)</b>	0.12°	0.25°	0.38°	0.51°	0.64°	0.76°

**Recommended Settings**



If the **FRONT OF THE WHEELS** are facing **OUT**, adjust the tie rods **OUT** or **INCREASE** the length of the tie rod.

Measurement at the front of the tires will be **GREATER** than the rear, if the **TOE IS OUT**.



If the **FRONT OF THE WHEELS** are facing **IN**, adjust the tie rods **IN** or **REDUCE** the length of the tie rod.

Measurement at the front of the tires will be **LESS** than the rear, if the **TOE IS IN**.



**IMPORTANT NOTE:** When tightening the tie rod jam nuts, the tie rod ends must be held parallel to prevent rod end damage and premature wear. Damage may not be immediately apparent if done incorrectly.

After alignment is complete, tighten & torque tie rod end jam nuts to specifications. [12-14 ft lbs]

## WARNING DECALS

---

25

***NOTICE TO DEALER, INSTALLER, AND VEHICLE OWNER:***

Any vehicle equipped with a portal gear lift must have the "WARNING Rollover Hazard" decals installed on the inside of the windshield or on the vehicle's dash, within driver's view.

***INSTALLING DEALER:***

It is your responsibility to install warning decals and forward these installation instructions to the vehicle owner for review of warnings, product use, and maintenance information. Replacement Warning Decals are available FREE upon request. These instructions are to be kept with the vehicle registration.

The **WARRANTY IS VOIDED** unless the official decals are in place.

## WARRANTY INFORMATION



### HIGH LIFTER LIMITED LIFETIME WARRANTY

High Lifter offers a Limited Lifetime Warranty to the original purchaser that our product shall be free from defects in material and workmanship for the life of the product if utilized in accordance with the manufacturer's instructions for installation and operation of said products.

#### LIMITED LIFETIME WARRANTY EXTENDS TO THE FOLLOWING PRODUCT LINES:

- Lift Kits (Signature, Standard and Big Lifts)
- Control Arms
- Trailing Arms
- Radiator Relocation Kits
- Portal Gear Lifts
- Wheel Spacers
- Tow Hooks
- Control Arm Link Kits
- Racks

Damages to vehicle or any other object during the installation, use, or removal of High Lifter products are not covered under this warranty. Normal wear items included with any of the products covered under this Limited Lifetime Warranty are excluded from coverage. These items include, but are not limited to heim joints, tie rods, bearings, bushings, seals, gaskets, zinc plating, painted and powder coated finishes. Other exclusions of coverage under this warranty include, but are not limited to: damage or product failure due to improper installation, lack of maintenance, product modification, abuse, collision or use on vehicles for which product was not designed, repairs performed by anyone other than approved High Lifter personnel or made using non-High Lifter components. This warranty is valid for the original purchaser only and is non-transferable. High Lifter reserves the right to inspect any product before determining if the claim is valid and covered under this warranty. Claims determined to be caused by reasons other than a manufacturer defect will be rejected and an estimate for repair or cost of a replacement product if a repair is not possible, will be provided.

**This warranty is exclusive** and is in lieu of any implied warranty of merchantability, fitness for a particular purpose or other warranty of quality, whether express or implied, except the warranty of title.

#### WARRANTY PROCESSING

If you suspect your product is defective, **DO NOT disassemble the product** to determine the cause without prior approval as it may void your warranty status. This is especially true with our Portal Gear Lift. To begin the claim process, please e-mail our warranty team at [warranty@highlifter.com](mailto:warranty@highlifter.com) and include the following in the e-mail:

- Your full name, address and contact phone number
- The year, make and model of your vehicle
- The part number of the product
- Photos of the product installed, and vehicle product is installed on
- Proof of purchase (Required for all warranty claims and you must be the original purchaser)

Once a claim is created, you will receive a return authorization number (RMA). Write this number on the outside of the box containing your defective product and include it along with your name and contact information inside the box. Product must be returned in the original box or a box of equal strength and packaging. Product sent without an RMA number visible on the outside of the box or sent COD will be refused. Ship your product to the following address:

High Lifter Products  
Attn: Returns 7455 Atkinson Dr, Shreveport, LA 71129

Once your product is received, we often have your replacement or repaired product shipped back to you within 3-business days of receiving it. Please note that **High Lifter is not responsible** for shipping charges on product returned for warranty or repair, including duties and fees required by those residing outside the United States.

THANK YOU FOR CHOOSING

# PORTAL WARRANTY INFORMATION

Thank you for purchasing a High Lifter Products Portal Gear Lift. Our Portal Gear Lifts have been engineered to provide superior performance on your ATV/UTV.

## LIMITED LIFETIME WARRANTY:

**HIGH LIFTER PRODUCTS**, warrants to the **ORIGINAL** purchaser of any Portal Gear Kit for a lifetime of protection from the date of purchase against defects in materials or workmanship, subject to the following conditions:

- a) The product must be properly installed according to all installation instructions.
- b) **HIGH LIFTER** is not liable for any incidental or consequential damages to anything other than the Portal Gear Kit covered by this warranty. **HIGH LIFTER** is not liable for any incurred expenses, labor costs to install/remove/reinstall Portal Gear Kit or any OEM or aftermarket components, loss of use of machine, damage to housings or damage to any aftermarket accessory or OEM components.
- c) If the Portal Gear Kit has been disassembled or modified by a third party, the warranty is null and void.
- d) Any Portal Gear Kit damaged in a collision with any object is excluded from this warranty. However, the Portal Gear Kit may be refurbished for a fee upon repair authorization by the owner. Costs will vary depending on the condition of each Portal Gear Kit assembly.
- e) Warranty is non-transferable from the **ORIGINAL** purchaser.
- f) **HIGH LIFTER** reserves the right to inspect the Portal Gear Kit for determining if there were any defects in the installation and to determine the validity of any warranty claim. The warranty process may require the **ORIGINAL** purchaser to provide photographs of the ATV/UTV and its installed Portal Gear Kit.
- g) Items that will not be covered under the warranty are but not limited to: Bearings, Seals, Gaskets, and Wheel Studs. All other components in kit are subject to review by **HIGH LIFTER** to determine reason for failure and if they meet requirements for warranty coverage.
- h) Warranty will be void on products that show; misapplication, improper installation, abuse, lack of proper maintenance, negligence, or alteration from original design.
- i) Any parts used to repair a portal kit must be purchased from **HIGH LIFTER** or warranty will be voided. For safety reasons it is important that the proper fastener grade, thread engagement, and torque specification be followed to prevent parts from failing. See instructions for torque data/specifications.

## REFUSED SHIPMENTS/ORDER CANCELLATION:

Refused shipments are subject to a 20% restocking fee plus all associated freight costs. It is our goal to ship all orders in a timely manner. If a customer wishes to cancel an order (provided it is not a special-order product), it is the responsibility of the customer to cancel the order prior to the product being shipped. If a customer cancels an order after product has been shipped, they refused shipment, cancellation, or return will be subject to a 20% restocking fee and any freight charges incurred. For orders outside the United States, any fees associated with customs or duties are non-refundable.

## DAMAGED SHIPMENTS:

All claims for damaged shipments must be made within 72 hours of delivery to the point of destination. Any damage to package should be noted with carrier at the time of delivery if possible. We will not be responsible for damage claims made over 72 hours after delivery to the point of destination.

## OBTAINING A WARRANTY CLAIM:

All returns for warranty must be pre-approved by calling 1.800.699.0947. After warranty approval has been granted and a Return Merchandise Approval (RMA) number issued, the Portal Gear Kit must be received by **HIGH LIFTER PRODUCTS** within 15 calendar days. The RMA number must be clearly displayed on the return box or the return will be refused. An RMA number does not imply that a replacement or refund will be issued on any product, but only that we will inspect the Portal Gear Kit for warranty claims. For orders outside the United States, any freight or fees associated with customs and duties are the responsibility of the purchaser and are non-refundable. All claims must be accompanied by the sales receipt detailing date and place of purchase, a written explanation of the problem, a phone number, and e-mail address. A copy of this receipt must be included with the Portal Gear Kit submitted for warranty repair or replacement. The purchaser is responsible for any freight charges on all warranty claims, including incoming freight to High Lifter and return freight to the purchaser.



RMA Number # \_\_\_\_\_

### HIGH LIFTER PRODUCTS WARRANTY CLAIM

Name: \_\_\_\_\_

Product Number: \_\_\_\_\_

Address: \_\_\_\_\_

Place of Purchase: \_\_\_\_\_

Phone Number: \_\_\_\_\_

Date of Purchase: \_\_\_\_\_

E-Mail Address: \_\_\_\_\_

Reason for Return: \_\_\_\_\_

Reminder – This claim must be accompanied by a copy of the original receipt.

# PRODUCT DISCLAIMER

## THE PRODUCT IS/WILL:

- Designed and intended for use on a UTV at slow speeds.
- Increase the center of gravity.
- Increase the turning radius.
- Increase the stopping distance when adding larger tires.
- Increase and accelerate wear of factory components including bushings, bearings, ball joints, and tie rod ends.
- We cannot guarantee fitment with other aftermarket accessories.

## Safety Guidelines:

- Inspect all moving factory suspension components particularly ball joints, tie rod ends, control arm connections, and brakes prior to each ride and replace if worn.
- Inspect clearances with control arms and brake lines prior to each ride.
- Wheel spacers should not be used with a Portal Gear Kit.
- 14" or larger wheels must be used with the Portal Gear Kit. 12" wheels cannot be used.
- Jumping, high speeds, and quick maneuvering should be avoided.

## Maintenance Information:

- Check gear oil in portal boxes following 25 hours of riding or sooner, depending on how you ride.
- Use 4 oz of SAE 80W-90 Gear Lubricant as needed in each portal box.
- Replace worn factory components including bushings, bearings, ball joints, brakes, and tie rod ends when they show wear.

Any vehicle equipped with a Portal Gear Kit must have the enclosed large format "Warning to Driver" decal installed on the inside of the windshield or on the vehicle's dash, within driver's view. The "Warning to Driver" decal is to act as a constant safety reminder for whoever may be operating the vehicle.

## INSTALLING dealer:

It is your responsibility to install the "Warning to Driver" decal and forward these installation instructions to the vehicle owner for review of warnings, product use, and maintenance information. Replacement Warning Decals are available FREE on request. These instructions are to be kept with the vehicle registration papers and owner's manual for the service life of the vehicle.

## REFUSED Shipments/Order CANCELLATION:

Refused shipments are subject to a 20% restocking fee plus all associated freight costs. It is our goal to ship all orders in a timely manner. If a customer wishes to cancel an order (provided it is not a special order product), it is the responsibility of the customer to cancel the order prior to the product being shipped. If a customer cancels an order after product has been shipped, refused shipment, cancellation, or return will be subject to a 20% restocking fee and any freight charges incurred. For orders outside the United States, any fees associated with customs or duties are non-refundable.

## DAMAGED Shipments:

All claims for damaged shipments must be made within 72 hours of delivery to the point of destination. Any damage to package should be noted with carrier at the time of delivery if possible. We will not be responsible for damage claims made over 72 hours after delivery to the point of destination.